

**THE  
LEGACY WALL  
TRAVELING  
INTERACTIVE  
LGBT HISTORY  
EXHIBIT**

**CORPORATE & CIVIC  
HOSTING PRIMER**



## **LEGACY WALL CORPORATE & CIVIC HOSTING**

---

### **BACKGROUND**

*The Legacy Project* is an award-winning (American History Association, 2014) Chicago-based 501(c)3 non-profit committed to researching and celebrating the contributions Lesbian, Gay, Bisexual, and Transgender (LGBT) people have made to world history and culture. The central tool of the organization's mission is "[The Legacy Walk](#)" – a growing half-mile outdoor installation featuring forty (40) bronze memorial markers affixed to the "Rainbow Pylons" on North Halsted Street which define the area as the cultural and business center of Chicago's large, diverse LGBT community. In cooperation with our partners at Illinois Safe Schools Alliance, the Legacy Project works to share the contributions of historically significant LGBT role models with our children, whose social isolation and cultural marginalization have left them vulnerable to bullying and loss of self-esteem. Raising awareness of the roles LGBT people have played in shared human history has been proven to lessen the incidence of all forms of bullying in our schools by encouraging a culture of mutual respect and tolerance.

### **THE LEGACY WALL**

In October 2015 the Legacy Project launched a one-of-a-kind traveling exhibit called "The Legacy Wall". After touring the State of Illinois for two years, it began a national tour in 2017. The Legacy Wall features the stories of LGBT people from all walks of life throughout history who have contributed in over 20 distinct fields. The content is international and multicultural, and has been substantially vetted and sourced. This wonderfully positive and inspiring exhibit tells the stories behind such figures as social justice pioneer Jane Addams, civil rights organizer Bayard Rustin, British mathematician Alan Turing, U.S. Congresswoman Barbara Jordan, astronaut Sally Ride, iconic artist Michelangelo, Fr. Mychal Judge (the "Saint of 9/11"), and acclaimed composers Pyotr Tchaikovsky and Leonard Bernstein – over 125 digitally interactive "mini-biographies" in all. This age-appropriate content is immensely enlightening for all audiences and produces powerful – often cathartic – responses in people.

### **HOSTING OPPORTUNITIES**

The Legacy Project offers corporate headquarters, cultural institutions, civic centers, colleges, universities, and libraries an opportunity to have this high-quality display installed in public areas for patrons and employees to casually peruse, or for use as part of community outreach efforts. This is an ideal way to engage multiple departments, employee resource groups, LGBT Campus Pride groups, GSAs, and local community groups in a shared, one-of-a-kind experience that celebrates LGBT contributions during this critical time in our history when the hard-fought gains we have achieved are now threatened by an unimaginable retreat from all that has been accomplished. For a tax-deductible hosting fee (plus transport-related and staff expenses) the Legacy Wall can be set-up for negotiable periods from two weeks to one month. The host institution is encouraged to consider a "preview" gathering for dignitaries and donors to "launch" the public viewing of the installation. We will work with local partners to help drive attendance using our website and the Legacy Project's broad-based social media following.

### **GENERAL DESCRIPTION**

The Legacy Wall is 24' long x 8' tall x 6' deep (see attached graphics)... nearly 400 square-feet of biographical content in a 360° doubled-sided island. In addition to a broad spectrum of historical content, the installation also highlights the challenges faced by LGBT youth with data culled from the GLSEN National School Climate Survey about the effectiveness of including LGBT-related content in general education for substantially lowering the incidence of bullying in our schools. The goal of the Legacy Wall is to use the powerful lessons of history to spark conversations about this information's ability to promote a feeling of safety and belonging in the classroom, to give our children hope by improving their outlook on life, and to raise cultural awareness.

**FOR MORE INFORMATION: Call 312-608-1198 or email [info@legacyprojectchicago.org](mailto:info@legacyprojectchicago.org)**

# A CELEBRATION OF LGBT ACHIEVEMENT

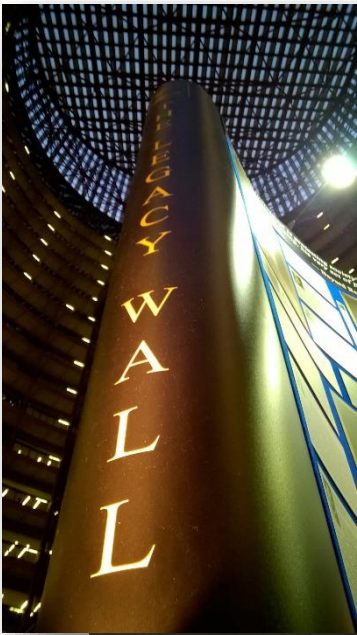

*International*



*Multicultural*

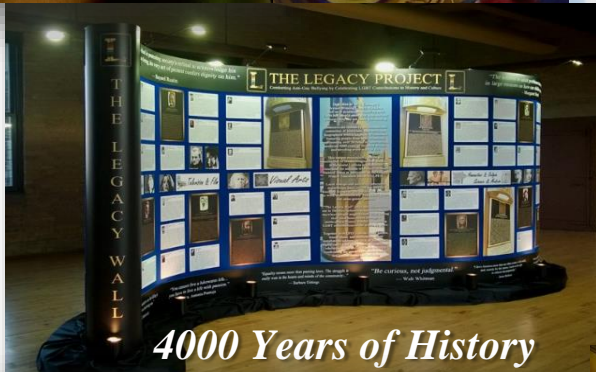

*4000 Years of History*

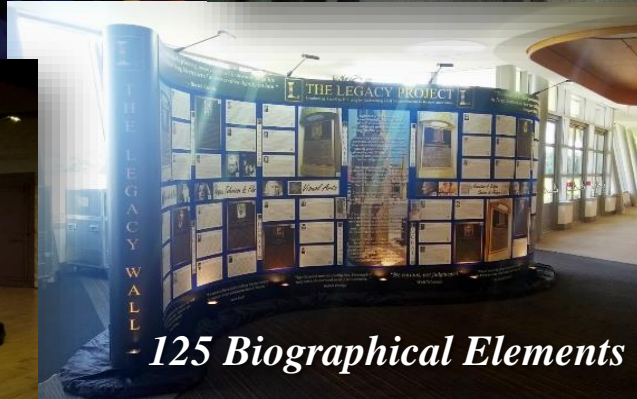

*125 Biographical Elements*



*Life-Affirming*



*Jaw-Dropping*



*Eye-Opening*



## THE LEGACY WALL

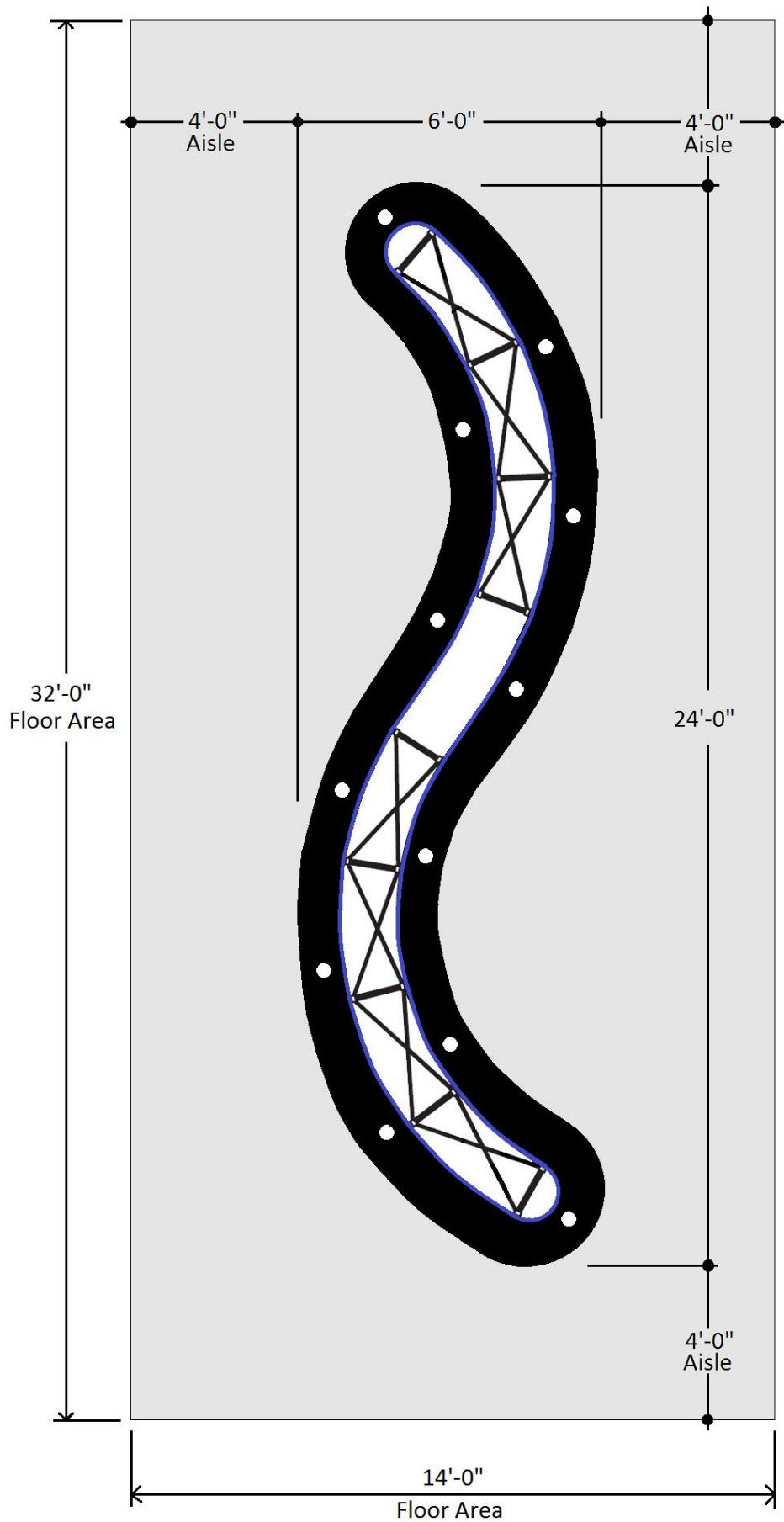

LEGACY WALL PLAN VIEW – NO SCALE

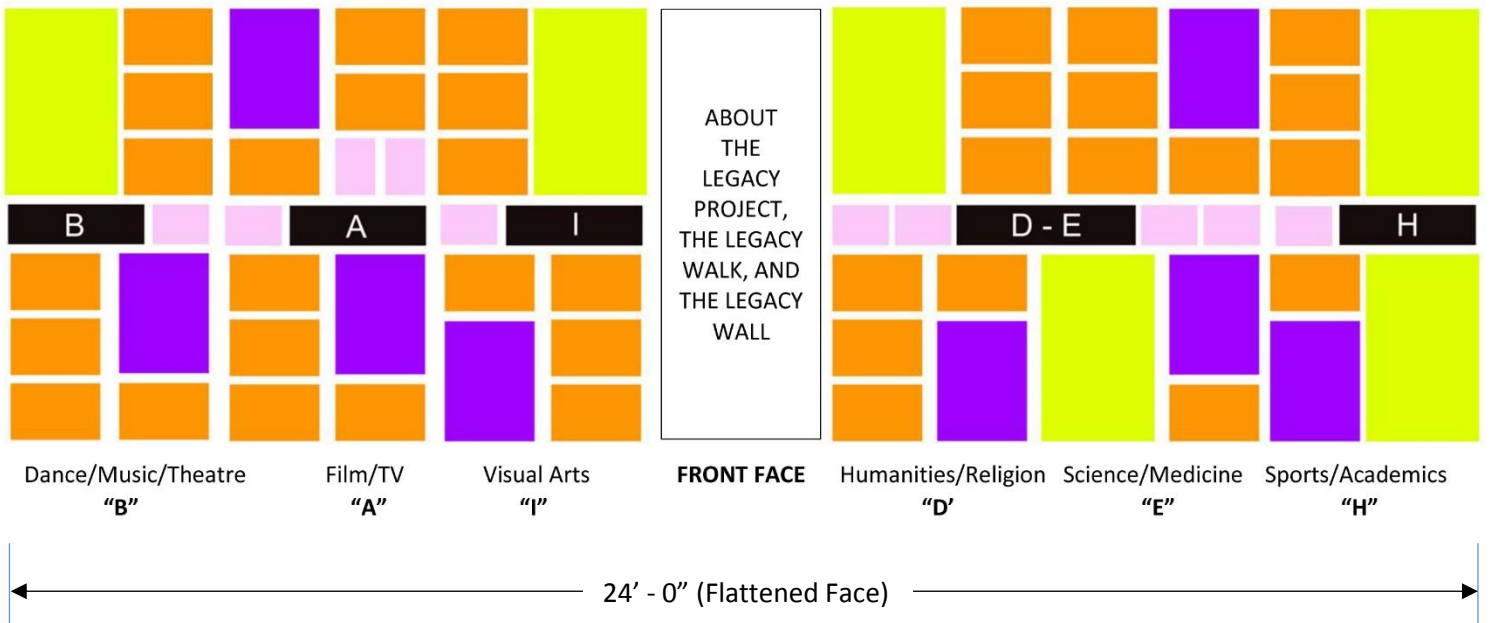
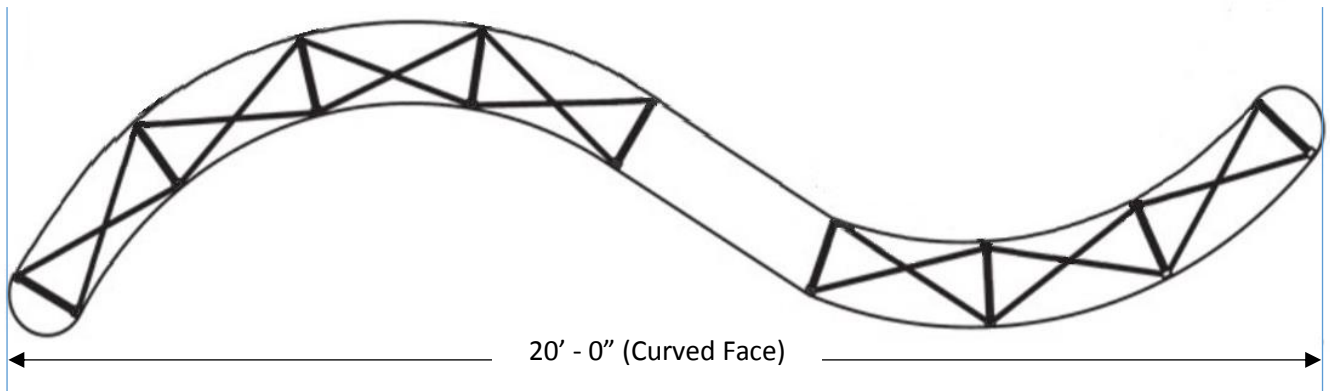
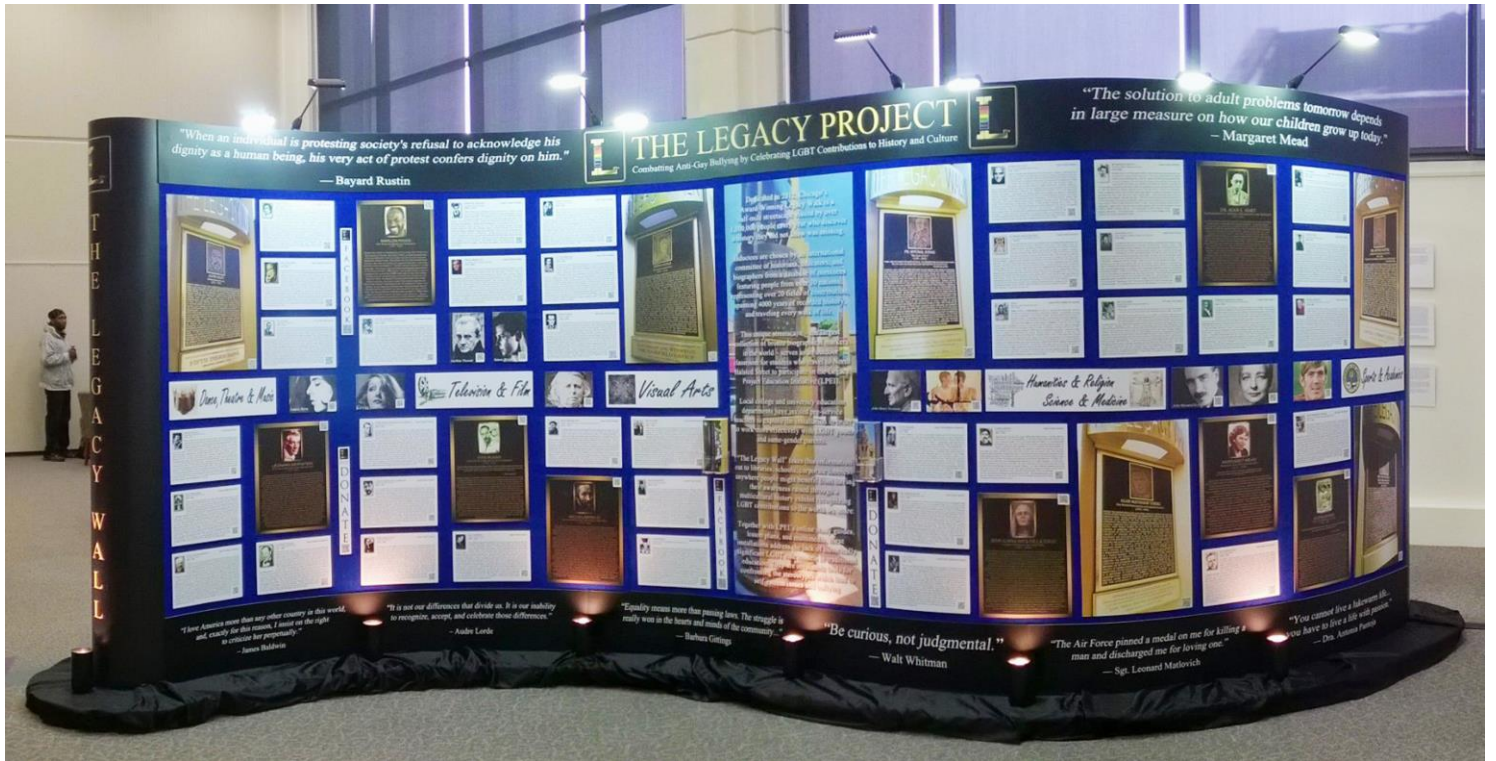

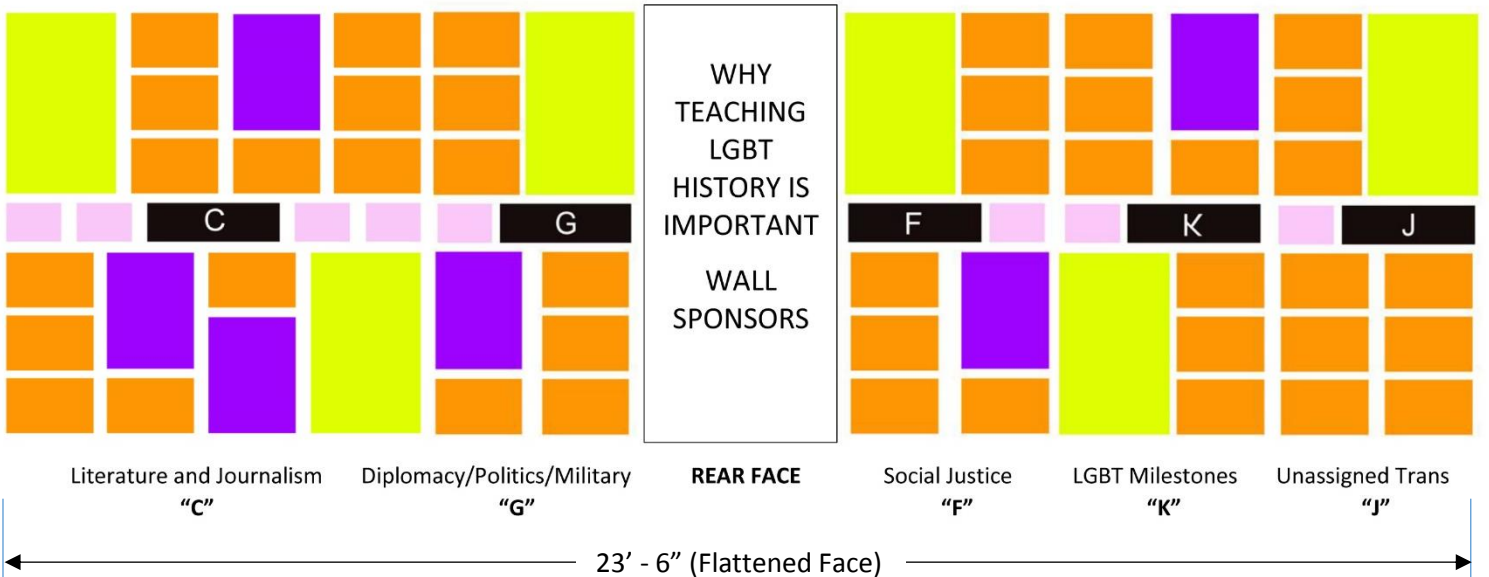
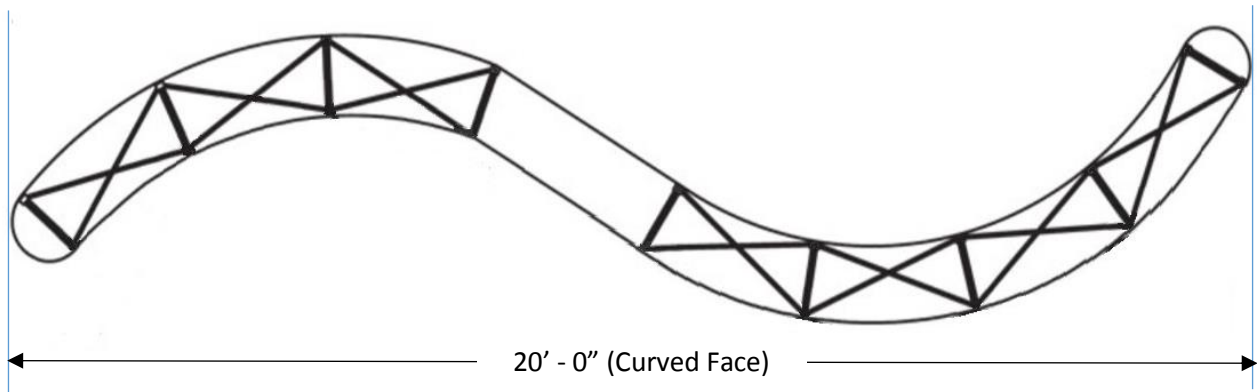

## **THE LEGACY WALL – Breakdown of Included Biographies and Images**

### **[A] FILM AND TELEVISION**

- 1) Nestor Almendros
- 2) Dorothy Arzner
- 3) Werner Fassbinder
- 4) Greta Garbo [P]
- 5) Ismail Merchant
- 6) Alla Nazimova
- 7) Marlon Riggs (C)
- 8) Vito Russo (C)
- 9) John Schlesinger
- 10) Luchino Visconti [P]
- 11) James Whale
- 12) Ramón Novarro [P]

### **[B] DANCE/MUSIC/THEATRE**

- 1) Alvin Ailey (I)
- 2) Rudolf Nureyev (I)
- 3) Lorraine Hansberry (I)
- 4) Leonard Bernstein (C)
- 5) Freddie Mercury
- 6) Laura Nyro [P]
- 7) Cole Porter (I)
- 8) Dusty Springfield (C)
- 9) Billy Strayhorn (C)
- 10) Tchaikovsky (C)

### **[C] LIT. & JOURNALISM**

- 1) Reinaldo Arenas (I) [P]
- 2) James Baldwin (I)
- 3) Katherine L. Bates
- 5) Jean Genet
- 6) Allen Ginsberg (C)
- 7) Radclyffe Hall
- 8) E. Lynn Harris
- 4) Essex Hemphill
- 9) Christopher Isherwood [P]
- 10) Audre Lorde (I)
- 11) Federico Garcia Lorca (C)
- 12) Carson McCullers [P]
- 13) Yukio Mishima (C)

### **[C] LIT. & JOURNALISM (Cont'd)**

- 14) Stein/Toklas (C)
- 15) Walt Whitman (I)
- 16) Oscar Wilde (I)
- 17) Virginia Woolf (C)
- 18) Lorena Hickok
- 19) Dorothy Thompson
- 20) Octavia Butler (C) [P]
- 21) Manuel Ramos Otero (C)
- 22) Wallace Thurman

### **[D] HUMANITIES & REL.**

- 1) Fr. Marsilio Ficino
- 2) Michel Foucault
- 3) Sor Juana (C)
- 4) Fr. Mychal Judge (I)
- 5) Kukai (C)
- 6) John Henry Newman [P]
- 7) Jeanne Deckers (C)
- 8) Sts. Sergius and Bachus
- 9) The Royal Manicurists [P]
- 10) Jean Cocteau
- 11) Marcel Proust

### **[E] SCIENCE AND MEDICINE**

- 1) Dr. Alan L. Hart (C)
- 2) Dr. Alfred Kinsey (I)
- 3) Ruth Benedict [P]
- 4) George Washington Carver
- 5) Leonardo Da Vinci
- 6) Margaret Mead (C)
- 7) Dr. Sally Ride (I)
- 8) Alan Turing (I)
- 9) John Maynard Keynes [P]
- 10) Dr. Michel Dillon

### **[F] SOCIAL JUSTICE**

- 1) Bayard Rustin (I)
- 2) Sylvia Rivera (C)
- 3) Jane Addams (I)

### **[F] SOCIAL JUSTICE (Cont'd)**

- 4) David Kato (I)
- 5) Two Spirit People
- 6) Frank Kameny (I)
- 7) Kiyoshi Kuromiya
- 8) Pauli Murray
- 9) Josephine Baker (C)
- 10) FannyAnn Eddy

### **[G] POLS/DIPLOMACY/MILITARY**

- 1) Sgt. Leonard Matlovich (I)
- 2) Frances Perkins (C)
- 3) Harvey Milk (I)
- 4) Barbara Jordan (I)
- 5) Baron Friederich Von Steuben
- 6) Alexander the Great [P]
- 7) Dr. Margaret Chung (I)
- 8) Dag Hammarskjöld (C)
- 9) Benjamin Sumner Wells
- 10) Willem Arondeus

### **[H] SPORTS & ACADEMICS**

- 1) Dr. Tom Waddell (I)
- 2) Dr. Antonia Pantoja (I)
- 3) Glenn Burke (C)
- 4) Babe Didrikson (I)
- 5) June Jordan (C)
- 6) Jerry Smith [P]
- 7) Elaine Locke
- 8) Dr. Hilda Hidalgo
- 9) Melvin Dixon

### **[I] ARTISTS**

- 1) Frida Kahlo (I)
- 2) Michelangelo (C)
- 3) Keith Haring
- 4) J. C. Leyendecker
- 5) Grant Wood
- 6) Beauford Delaney

## **THE LEGACY WALL – Breakdown of Included Biographies and Images (Cont'd)**

### **[I] ARTISTS (Cont'd)**

- 7) Leigh Bowery
- 8) Romaine Brooks
- 9) Greer Lankton
- 10) Rosa Bonheur [P]

### **[J] TRANSGENDER (Not Included Elsewhere)**

- 1) Christine Jorgensen (I)
- 2) Lili Elbe
- 3) Candy Darling
- 4) Marsha P. Johnson
- 5) Charlie Parkhurst
- 6) Albert D.J. Cashier
- 7) Angela Morley
- 8) Billy Tipton
- 9) Antonio De Erauso
- 10) Amelio Robles Avila
- 11) Coccinelle [P]

### **[K] MILESTONES**

- 1) Stonewall (I) Revolution
- 2) Pink Triangle (C) Homosexual Victims of the Holocaust
- 3) The Harlem Renaissance (First Urban LGBT Community)
- 4) DADT/Repeal (Gays in the Military)
- 5) SHC/SHR (Earliest Rights/Advocacy)
- 6) Olesen (LGBT Information through the Mail)
- 7) APA (Mental Illness Diagnosis Struck Down)
- 8) Hardwick/Lawrence (Sodomy Laws Struck Down)
- 9) Romer (LGBT Civil Rights Laws Upheld)
- 10) MARRIAGE: Prop 8/Windsor/Obergefell [P]



## GLSEN NATIONAL SCHOOL CLIMATE SURVEY

This highly reduced panel (1/8 scale) is the core component of The Legacy Wall's exploration of the relationship between the type of content housed on the installation, and the impact of bringing it into the classroom. The actual panel on the installation is 30" x 36". Viewers will be able to download the entire GLSEN National School Climate Survey via an embedded link.

### SOMETIMES HISTORY GETS SET A LITTLE TOO STRAIGHT

LGBT contributions to world history and culture have been so redacted that our children are forced to grow up without historically significant LGBT role models. This makes education less relevant for them – contributing to social isolation, cultural marginalization, and serious loss of self-esteem – the primary drivers of anti-gay bullying and suicide. Studies like the National School Climate Survey, conducted by the Gay, Lesbian, and Straight Education Network (GLSEN), reveal that LGBT-inclusive content, when incorporated as part of general education, markedly improves school climates by encouraging an atmosphere of acceptance which leads to a lower incidence of bullying, violence, and verbal abuse. The statistics shown on the graphs below are drawn from a final sample which consisted of a total of 10,528 students between the ages of 13 and 21. Students were from all 50 states and the District of Columbia and from 3,095 unique school districts. About two thirds of the sample (68.6%) was White, slightly more than one third (34.9%) was cisgender female, and just under half identified as gay or lesbian (49.2%). Students were in grades 6 to 12, with the largest numbers in grades 10 and 11.

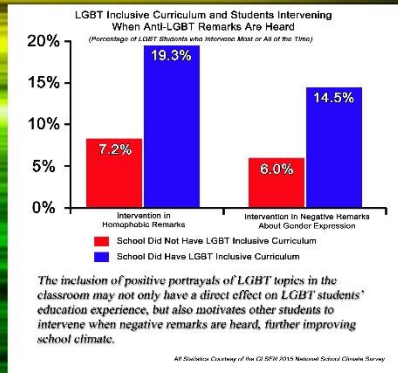
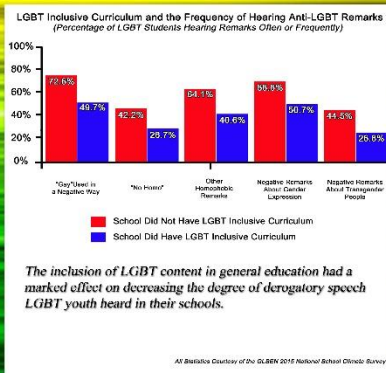
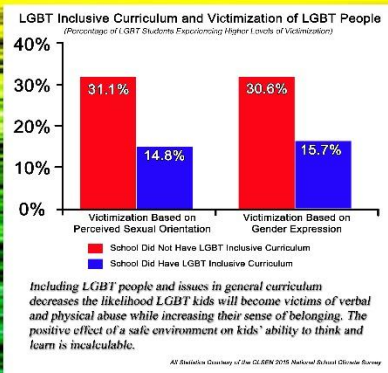

## Scan the code to download the entire GLSEN National School Climate Survey:

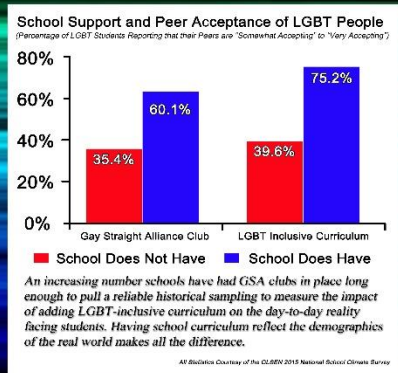
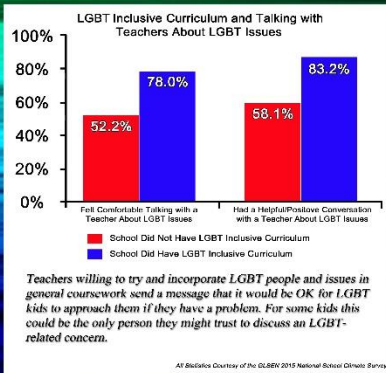
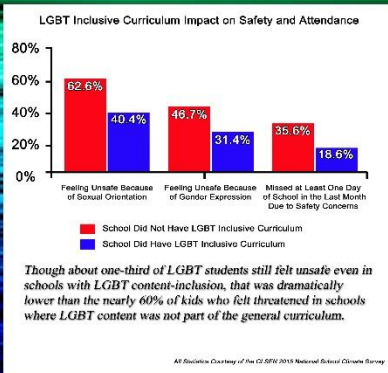

The invaluable work of the Gay, Lesbian, and Straight Education Network (GLSEN) helps us to understand the underlying causes of LGBT youth challenges in our schools – and points the way to a solution that will have far-reaching consequences for the next generation. LGBT content inclusion improves the prospects for future educational gains and a productive life for LGBT youth who are often marginalized on multiple fronts simultaneously. Sharing this information opens a doorway to inspiration and possibility by showing that LGBT people have made tremendous contributions to every field imaginable across history – and almost always under extremely difficult circumstances. This provides a sense of belonging most will never get anywhere else, as well as a reason to steward forward the gains that have made open lives possible for LGBT people today. For those who are not LGBT it encourages appreciation and understanding where stereotypes and mythology are all too often the norm. Until our schools can be freed to rise to this challenge, it is important that LGBT adults and their allies find other ways to counter the institutional redaction of LGBT people.

## WHY LEARNING ABOUT LGBT HISTORY MATTERS

## **LEGACY WALL PROPOSED DISCUSSION TOPICS (IN FORMATION)**

- What does it mean to you personally to have an installation like “The Legacy Wall” visit your community? How would you describe it to someone? Do you know people who will want to see it? Who would be opposed to seeing it?
- The information contained on “The Legacy Wall” has been almost entirely redacted from conventional historical narratives. Why do you think that has been the case? What have the consequences been for society? For individuals?
- In what way do you think sharing the information represented on “The Legacy Wall” might affect your own community? Could anyone in your community benefit from it? Why or why not?
- Would you oppose or support bringing the content represented on “The Legacy Wall” more directly into schools? Would you consider integrating age-appropriate lesson plans and study resources into general education about various times in history and fields of contributions in different areas of study? Why or why not? Would it matter to you? To anyone you know?
- Being “In” or “Out” of “The Closet” has most often been used to describe the status of persons in the LGBTQ community. Do you understand this concept? Please explain. Why do think it came to be? How would you describe the impact of “The Closet” on people’s lives? On society?
- “The Legacy Wall” reveals some information discovered about people after their deaths, based on newly available historical research. Do you feel it is appropriate to examine the impact of life details such as hidden medical conditions, secret relationships, covert political alliances, variant sexuality, and/or undisclosed business dealings on the legacy of persons who have passed if they did not reveal that information prior to their deaths?
- Would you agree or disagree that sometimes viewing a life through different lenses can reveal greater understanding of an historic figure’s motivations?
- The GLSEN School Climate data that has been incorporated into “The Legacy Wall” juxtaposes statistics about the impact of LGBT content inclusion on school environments with examples of the kind of content that might be shared. How do you feel about seeing this information in this setting?
- What would be the “upside” of having this content become part of shared public knowledge? What might be the “downside”?